

HC900 Controller Redundancy Overview & System Operation

Doc. No.: 51-52-25-133
Revision: 3
Date: 9/06

Notices and Trademarks

**Copyright 2006 by Honeywell
Revision 3 Sept. 2006**

Warranty/Remedy

Honeywell warrants goods of its manufacture as being free of defective materials and faulty workmanship. Contact your local sales office for warranty information. If warranted goods are returned to Honeywell during the period of coverage, Honeywell will repair or replace without charge those items it finds defective. The foregoing is Buyer's sole remedy and is in lieu of all other warranties, expressed or implied, including those of merchantability and fitness for a particular purpose. Specifications may change without notice. The information we supply is believed to be accurate and reliable as of this printing. However, we assume no responsibility for its use.

While we provide application assistance personally, through our literature and the Honeywell web site, it is up to the customer to determine the suitability of the product in the application.

Industrial Measurement and Control

Honeywell
1100 Virginia Drive
Fort Washington, PA 19034

HC900, 559 and 1042 are U.S. registered trademarks of Honeywell

Other brand or product names are trademarks of their respective owners.

About This Document

Abstract

This manual gives an overview of the HC900 Redundancy architecture and products.

References

The following list identifies all documents that may be sources of reference material for topics discussed in this publication.

Document Title	Doc ID
HC900 Hybrid Controller Specification	51-52-03-31
559 and 1042 Operator Interface Specification	51-52-03-32
HC900 Module Specification	51-52-03-41
Hybrid Control Designer Specification	51-52-03-43
HC900 Controlware Specification	51-52-03-42
HC900 Hybrid Controller Installation and User Guide	51-52-25-107
OPC Server User Guide	51-52-25-134
HC900 Hybrid Control Designer User Guide	51-52-25-110
HC900 Hybrid Control Utilities User Guide	51-52-25-126
HC900 Hybrid Control Designer Function Block Reference Guide	51-52-25-109
HC900 Hybrid Controller Communications User Guide	51-52-25-111
1042 & 559 Operator Interface User Guide	51-52-25-108

Contacts

World Wide Web

The following lists Honeywell's World Wide Web sites that will be of interest to our customers.

Honeywell Organization	WWW Address (URL)
Corporate	http://www.honeywell.com
Industrial Measurement and Control	http://content.honeywell.com/imc/
IM&C Technical tips	http://content.honeywell.com/ipc/faq









Telephone

Contact us by telephone at the numbers listed below.

Organization		Phone Number	
United States and Canada	Honeywell	1-800-423-9883	Tech. Support
		1-800-525-7439	Service

Symbol Definitions

The following table lists those symbols that may be used in this document to denote certain conditions.

Symbol	Definition
	This DANGER symbol indicates an imminently hazardous situation, which, if not avoided, will result in death or serious injury .
 WARNING	This WARNING symbol indicates a potentially hazardous situation, which, if not avoided, could result in death or serious injury .
 CAUTION	This CAUTION symbol may be present on Control Product instrumentation and literature. If present on a product, the user must consult the appropriate part of the accompanying product literature for more information.
CAUTION	This CAUTION symbol indicates a potentially hazardous situation, which, if not avoided, may result in property damage .
	WARNING PERSONAL INJURY: Risk of electrical shock. This symbol warns the user of a potential shock hazard where HAZARDOUS LIVE voltages greater than 30 Vrms, 42.4 Vpeak, or 60 Vdc may be accessible. Failure to comply with these instructions could result in death or serious injury.
	ATTENTION, Electrostatic Discharge (ESD) hazards. Observe precautions for handling electrostatic sensitive devices
	Protective Earth (PE) terminal. Provided for connection of the protective earth (green or green/yellow) supply system conductor.
	Functional earth terminal. Used for non-safety purposes such as noise immunity improvement. NOTE: This connection shall be bonded to protective earth at the source of supply in accordance with national local electrical code requirements.
	Earth Ground. Functional earth connection. NOTE: This connection shall be bonded to Protective earth at the source of supply in accordance with national and local electrical code requirements.
	Chassis Ground. Identifies a connection to the chassis or frame of the equipment shall be bonded to Protective Earth at the source of supply in accordance with national and local electrical code requirements.

Contents

Symbol Definitions.....	v
Introduction	1
Overview.....	1
Purpose of this document.....	1
What's in this document	1
Documentation	1
Purpose of the product.....	2
Product architecture	2
Key components	3
Redundant Controller Rack.....	3
CPU	4
Power.....	4
Redundant Switch Module (RSM).....	4
Remote I/O Racks	5
Dual-Port Scanner2 Module.....	5
Power Status Module	5
I/O Modules.....	6
Operator Interfaces & Serial Ports	6
Networking	7
System Network	7
System Network Supervisory Functions.....	8
To PC Applications.....	8
To Peer HC900 Controllers.....	9
Connection options	9
I/O Network to Remote Racks	10
Device Network (Serial).....	11
Modbus Master	11
Modbus Slave	11
Modbus Master and/or Slave	11
Remote Access	11
Configuration.....	12
Lead Controller configuration	12
Configuration & Setup Parameters for Redundant Controllers.....	12
Reserve Controller configuration.....	12
Software	13

HC Designer & HC Utilities PC Software.....	13
Downloading configuration from PC to controller	13
Configuration storage	13
Configuration edits	13
Uploading configuration from controller to PC.....	14
Downloading to multiple controllers.....	14
Configuration backup	14
Configuration conversion.....	14
Monitoring configurations	14
Operation	15
Overview.....	15
Start-Up	15
Modes of operation.....	15
RUN Mode (Locked)	16
RUN/PROGRAM Mode (Unlocked).....	16
PROGRAM Mode (Locked).....	16
Steady State Operations	16
Execution time.....	17
Execution sequence.....	17
Lead/Reserve controller synchronization	17
Failover.....	18
Automatic Failover	18
Manual Failover.....	19
Failover Performance	19
Redundancy Diagnostic Monitoring.....	19
Installation	20
Installing the Redundant Controller Rack.....	20
Installing the I/O Racks.....	20
Installing Networking Equipment	21
I/O Network	21
Supervisory / Peer Network.....	21
Installing a Panel-Mounted Operator Interface	21
Honeywell OI-1042 & OI-559	21
3rd Party Panel-Mounted OI.....	21
Installing PC Hosts	22
Honeywell HC Designer & HC Utilities Software	22
Honeywell Vista Software.....	22
3rd Party PC Application Software	22
Troubleshooting	23
Diagnostic Indicators	23
Diagnostic Monitoring from HC Designer and HC Utilities PC Software.....	23
Status data available via Supervisory PC	23
Servicing.....	24
Module Replacement	24
C70R Module Replacement	24
Redundancy Switch Module Replacement.....	24

Scanner2 Module Replacement	24
C70R Power Supply Replacement.....	24
Non-Redundant Power Supply for I/O Rack Replacement.....	24
Optional Redundant Power Supply for I/O Rack Replacement	24
Power Status Module Replacement.....	25
I/O Module Replacement.....	25
Sales and Service	26

Figures

Figure 1 HC900 Redundant Controller architecture	2
Figure 2 Redundant controller rack components	3
Figure 3 Ethernet switch with redundant controller	7
Figure 4 Redundant Ethernet switches with redundant networks	8
Figure 5 Peer Data Exchange, Redundant Controllers, Non-Redundant Network	9
Figure 6 Peer Data Exchange, Redundant & Non-Redundant Controllers, Non-Redundant Network	9
Figure 7 Peer Data Exchange, Redundant Controllers, Redundant Networks	10
Figure 8 Connection from Lead controller to PC	12
Figure 9 Modes of operation on RSM	16
Figure 10 Lead/Controller synchronization	18

Introduction

Overview

Purpose of this document

Provide an overview of the Redundant HC900 product.

What's in this document

Topic	Page
Purpose of the Product	2
Product Architecture	2
Key Components	3
Networking	7
Configuration	12
Operation	15
Installation	20
Troubleshooting	23

Documentation

See References on page iii.

Purpose of the product

The HC900 Controller with redundancy minimizes the impact on a process resulting from a single failure of a critical component of the control system. Availability is improved with:

- Redundant Controller Processors - Provides redundant controllers with seamless failover under fault conditions,
- Independent power supplies for each of the Redundant Controllers,
- Redundant host networks - Provides interfaces to survive a single network failure,
- Redundant I/O Power – Provides redundant power for I/O racks on a per rack basis.

Product architecture

The Redundant HC900 controller uses a separate rack for controller processors mounted separately from I/O Racks

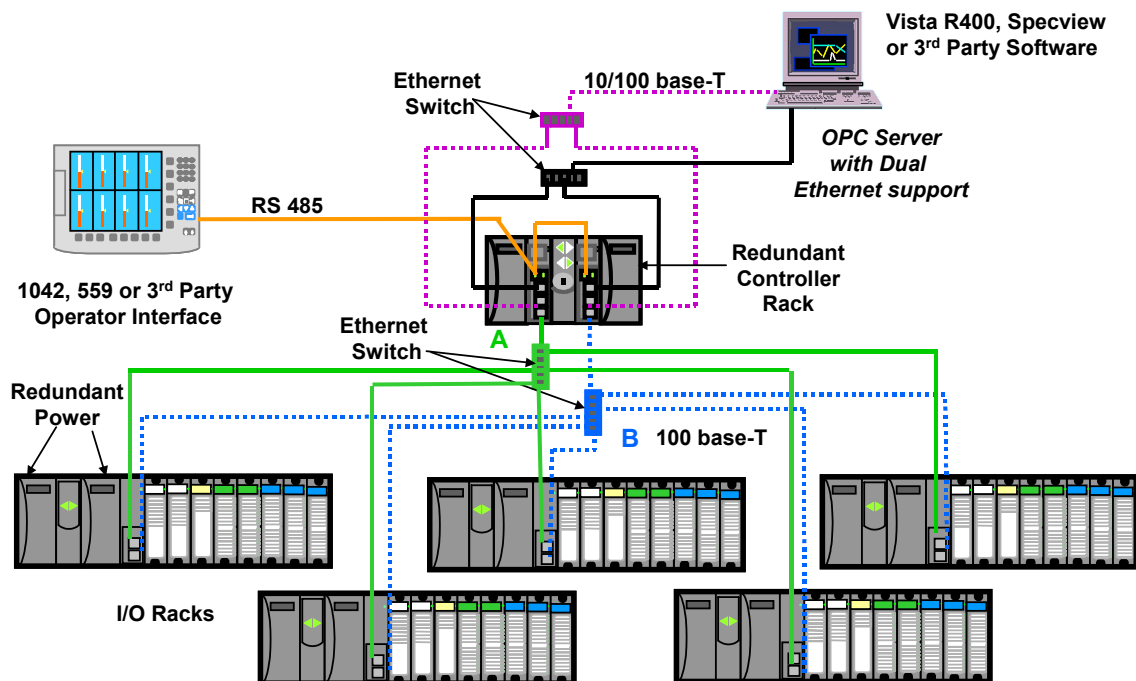

Figure 1 HC900 Redundant Controller architecture

Key components

Redundant Controller Rack

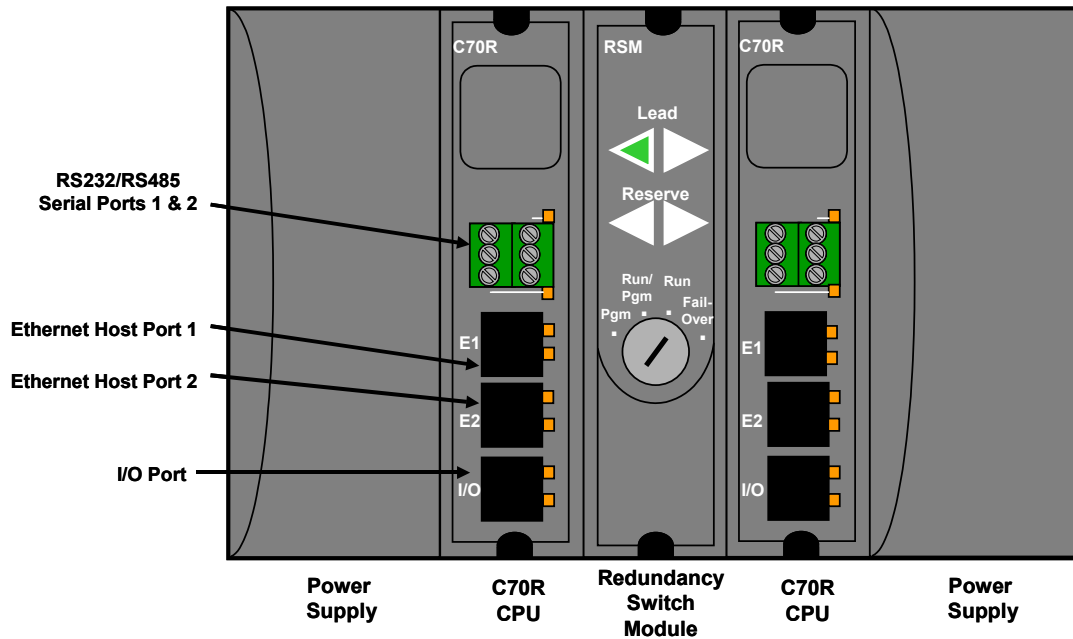

Figure 2 Redundant controller rack components

- Holds two redundant C70R CPUs, two power supplies, and one Redundancy Switch Module (RSM).
- Contains the back-plane for C70R-to-C70R communications, power, and interface to RSM.
- The C70R Controller Rack does not support any I/O Modules; I/O Modules are read from and written to directly from a Scanner2 CPU.
- Cannot be used with C30 or C50 CPU's.

CPU

- Requires Scanner2 module(s)
- Reads inputs from I/O Racks through Scanner2 modules
- Executes control strategy (5000 function blocks)
- Writes outputs to I/O Racks through Scanner2 modules
- Dual Ethernet communication ports to host systems
- Each C70R Controller CPU has a dedicated, single Ethernet communication port to I/O racks
- Two serial ports – each is RS-232 or 485 configurable; Modbus or ELN protocols for interface to OI, Modbus Host, or Modbus Slaves
- Lead Controller CPU – writes to the physical outputs; serves as the single external interface to other devices and systems (i.e., responds to requests from PC Hosts, a local Operator Interface, communicates to HC900 peers, and polls network slave devices)
- Reserve Controller CPU – executes control strategy in sync with Lead but does not write to physical outputs; does not respond to Hosts or OI.
- Reserve Controller CPU receives configuration updates and run-time data (operator entries, supervisory changes) from the Lead CPU with no manual user interaction. Configuration changes to a Reserve CPU are not permitted, except through the Lead CPU where both CPUs receive the change.
- The C70R is not recommended for non-redundant applications.

Power

- Each C70R CPU has a dedicated Power Supply (two in the controller rack). Failure of the Lead CPU power supply will cause a failover condition.
- The same power supply model(s) are used for the controller rack and the I/O racks.
- The same power supply models(s) are used for the redundant and non-redundant systems.

Redundant Switch Module (RSM)

- One RSM is installed in the redundant controller rack.
- Provides indicators to identify Lead and Reserve Controller CPU's.
- Provides a key switch to set the controller mode (RUN, PROGRAM, RUN/PROG), and to force a manual failover from the Lead to the Reserve. The Reserve CPU tracks the mode selection of the Lead CPU.
- RSM may be replaced under power.

Remote I/O Racks

- Each CPU has a separate Ethernet 100base T physical connection for up to 5 Remote I/O racks.
- Racks are available in three sizes: 4 I/O modules, 8 I/O modules, 12 I/O modules
- Systems with only one remote rack may have the remote rack connected directly to the CPU without a switching hub.
- Systems with more than one remote rack require a separate switching hub for each CPU connection. The switching hubs used in the I/O network must be Honeywell recommended industrial grade hubs.
- Remote racks require a dual-ported Scanner2 module to interface with the Redundant Controllers.
- Remote racks hold one Scanner2 module, one power supply, and up to 4, 8, or 12 I/O modules.
- The 8 and 12 Slot racks are available with a redundant power supply option. A Power Status Module (PSM) provides power supply status when two power supplies are used.
- The PSM monitors the power supply outputs and turns the green status LED off if a fault is detected.
- The load is distributed between the two supplies during normal operation when two power supplies are used.
- Racks with four I/O slots do not support the redundant power option.

Dual-Port Scanner2 Module

- Reads inputs from the modules in the rack.
- Writes outputs to the modules in the rack.
- Has two Ethernet ports – one dedicated to each of the redundant C70R Controller CPU's
- Maintains communications with both Lead and Reserve C70R CPU's to facilitate failover.
- One Scanner2 Module is installed in each I/O Rack
- Required for the interface to C70R redundant controllers (cannot use non-redundant Scanner modules with C70R CPUs)

Power Status Module

- Indicates current status of both Power Supplies
- May be replaced under power

I/O Modules

- The full complement of HC900 Analog and Digital I/O modules are available for use in I/O racks using the Scanner2 module connected to redundant C70R Controller CPU's.
- Requires Digital I/O modules with model numbers 900xxx-0102 or later with enhanced I/O back-plane performance and shield modification.
- Requires Analog Input modules 900A01-0102 or later with shield modifications.
- Requires Analog Output modules 900B01-0101 or later with shield modifications.
- Any module may be inserted into any rack slot location.
- Redundant I/O modules are not supported in the HC900 system.

Operator Interfaces & Serial Ports

- The C70R CPU provides two user-selectable RS232 or RS 485 serial ports. A Honeywell 1042 or 559 operator interface may be connected to either of the ports when configured as RS 485 and ELN protocol.
- Only one Honeywell operator interface may be connected to a controller.
- Lead controller communicates with the operator interface.
- Baud rates of 38.3K and 57.6K are supported for communications to 1042 and 559 Operator Interfaces for distances up to 2000 feet, 610M.
- The RS 485 twisted pair cable should be connected to both C70R CPUs of a redundant system to maintain communication following a failover event. .
- The same serial port (S1 or S2) must be used on both CPUs of a redundant system to maintain compatibility with the common configuration.
- Failure of a CPU will cause the second CPU to assume the serial port function.
- Failure of a serial port of the Lead controller will not cause a failover of the CPU.
- The S1 and S2 serial ports may also be used to interface the controller to 3rd party operator interfaces using either RS232 or RS 485 and Modbus RTU slave protocol.

Networking

System Network

Each C70R CPU provides two 10/100base T Ethernet Host ports with Modbus TCP protocol. A total of 10 sockets are available and are shared by the two ports of the CPU for host device interfacing. Either port may be used in a non-redundant connection for host systems that do not support redundant network communications.

- Requires Honeywell (PN 50008930-001) or commercially available industrial switches, routers, etc for 10/100-baseT connection to the host/peer network. See **Figure 3**.
- Supports single or dual network interface to PC Hosts.
- Supports single or dual network interface to peer HC900 Redundant Controllers.
- Supports single network interface to peer HC900 Non-Redundant Controllers or other Modbus/TCP devices.
- Network changes such as setting IP addresses must be made with the controller in the Program mode. See Modes of operation on page 15.
- Maximum distance of system network (per 10/100 baseT specification, 100 meters per segment).

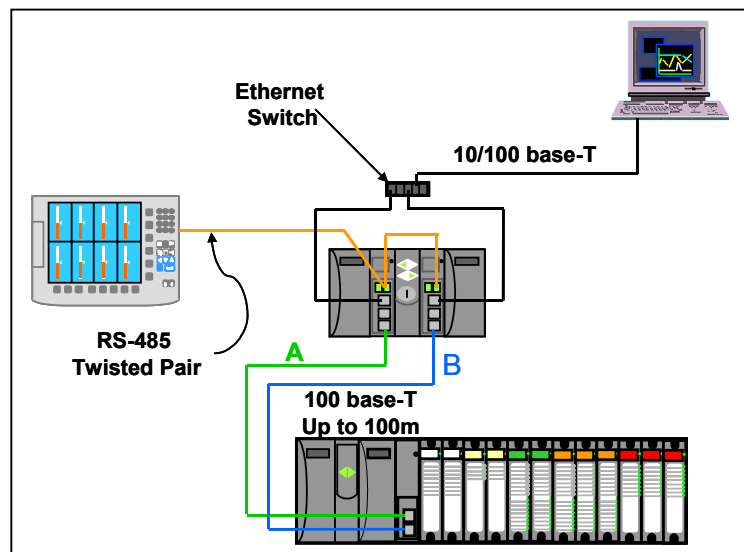

Figure 3 Ethernet switch with redundant controller

For applications where the host supports redundant networks, two separate Ethernet switches are required, one for each port of the CPUs. See Figure 4.

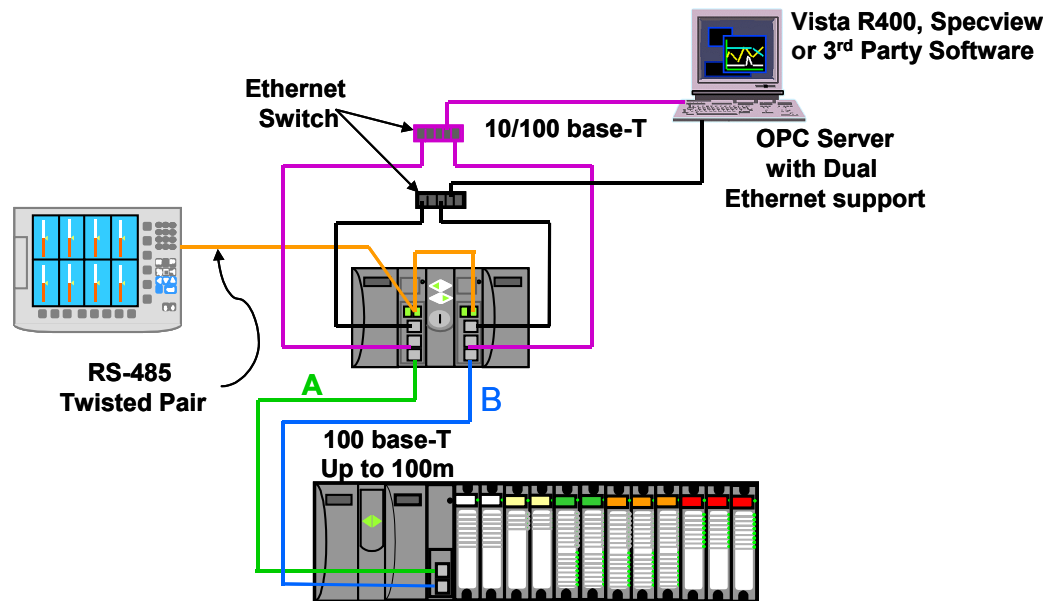

Figure 4 Redundant Ethernet switches with redundant networks

In this configuration a second communication path is available between the Host and the controller in the event of a switching hub or connection failure.

System Network Supervisory Functions

To PC Applications

Network communications of a host system to the controller is directed to the Lead controller. Communication to the Reserve controller is not supported. Following a failover event, the new Lead controller assumes this function.

- Native Applications – HC Designer & HC Utilities
 - Communicate to HC900 Controllers over Ethernet
 - Applications provide a choice of either a single port to verify proper port operation, or two ports with automatic connection where the PC will use the first available port capable of communicating to the controller.
- OPC Client Applications - Honeywell's OPC server is a PC application with an embedded communication driver to support simplex and redundant network communications to HC900 controllers and other Modbus/TCP compatible devices. The database export files generated by Hybrid Control Designer software may be used to transfer the database from the controller to the application, minimizing the amount of user entered data needed to apply the application. The OPC server is used to interface products such as Vista and Specview to HC900 controllers with dual Ethernet capability.
- Supports single or dual network interface to C70R CPUs
- Communicate to Honeywell Vista Software

- Communicate to 3rd Party OPC-Client aware PC applications
 - Communicate to HC900 Controllers over Ethernet
 - OPC server detects a failure of an Ethernet connection and automatically fails-over to a second port.

To Peer HC900 Controllers

- Peer-to-Peer communications to C30, C50, or other C70R Controllers
- Lead Controller handles all peer communications
- Automatic failover of function to the new Lead Controller
- Auto-Discovery of peer network addresses; Easy to configure & set-up
- Peer controllers do not consume Ethernet sockets.
- A controller can support up to 8 peers in its configuration database.

Connection options

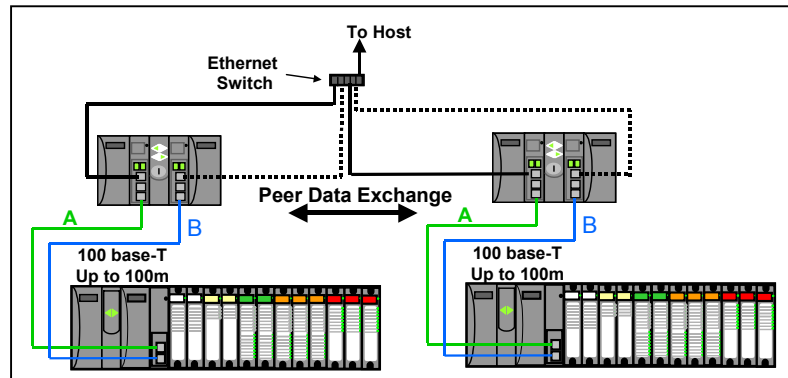

Figure 5 Peer Data Exchange, Redundant Controllers, Non-Redundant Network

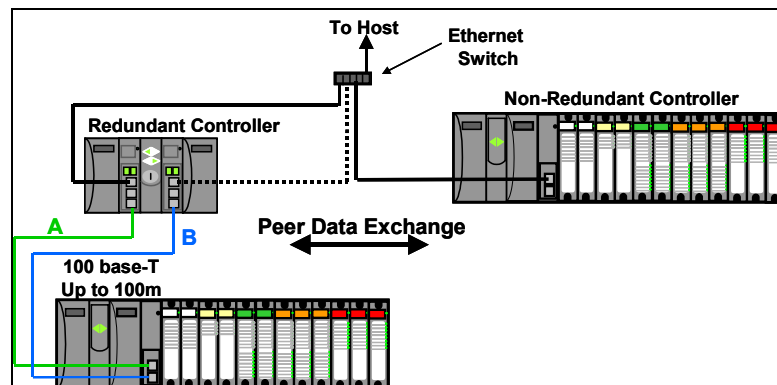

Figure 6 Peer Data Exchange, Redundant & Non-Redundant Controllers, Non-Redundant Network

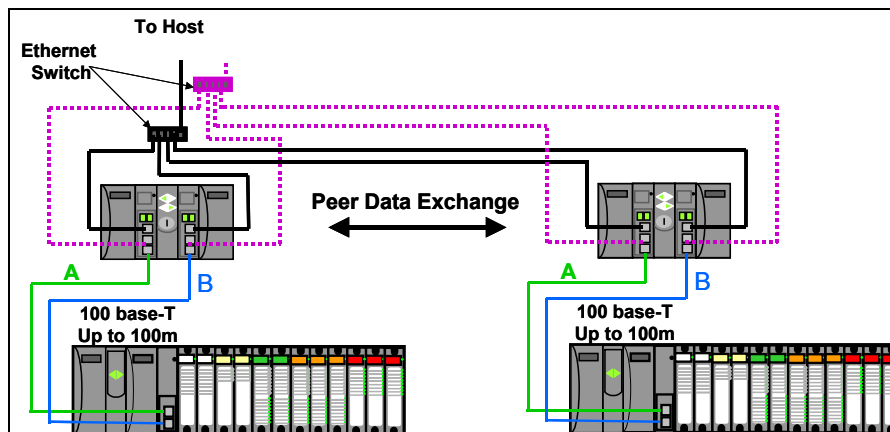

Figure 7 Peer Data Exchange, Redundant Controllers, Redundant Networks

I/O Network to Remote Racks

- IEEE 802.4 Physical Layer Ethernet
- Two networks must be used for the I/O rack connections in a redundant system, one for each C70R CPU. See Figure 1.
- May be direct connected for single I/O rack systems.
- Two Ethernet switching hubs must also be used for installations with 2 or more I/O racks
- **Must use Honeywell recommended industrial grade switching hubs (PN 50008930-001). Performance of the system is not warranted if an alternate switching hub is used for this connection.**
- Up to 5 I/O Racks per configuration
- Separate hub required for interface from each C70R CPU
- Requires Ethernet cable: Shielded CAT5 cable with RJ-45 connectors.
- Maximum distance from Redundant Controller Rack to I/O Racks is 100 meters without hubs, 300 meters using two hubs. Fiber optic cable and switches can extend distance to up to 1500 meters.

Device Network (Serial)

Modbus Master

- RS-485 Serial Interface with Modbus RTU Protocol
- Two ports available, each can be set as a Master or Slave.
- Only one of the two ports may be selected for Modbus RTU Master operation.
 - The same port on each CPU must be used for this function to maintain consistency between controller configurations.
 - Both CPUs of the redundant controller should be connected to the slave devices.
- Up to 16 Slave Devices supported per configuration.
- Up to 384 total slave register addresses supported per configuration.

Modbus Slave

- The two serial ports of the C70R CPU may each be set to RS 485 or RS 232 and Modbus slave operation.
- Supports data exchange with an external Modbus master such as a local operator panel or PC application.
- Port connections to redundant C70R CPUs should be made to both CPUs in the rack.
- Uses same local Modbus unit address for both RS 485 serial ports of the two C70R CPUs.
- A modem configuration selection extends the 3-character timeout limit of Modbus protocol for remote access.

Modbus Master and/or Slave

- Lead Controller transmits on the link.
- Automatic failover of Master/Slave functions to the new Lead Controller.
- Failure of the Modbus Master serial port of the Lead Controller will not cause a failover of the CPU.
- Supports transmission speeds from 1200 to 57600 baud.
- Up to 609 Meters, 2000 feet, total network length

Remote Access

- Requires an external modem.
- Available with HC Designer software.
- Lead Controller provides communications.

Configuration

Lead Controller configuration

- Develop the initial control strategy or convert C30 or C50 configurations.
- Make incremental changes to existing control strategies as required.
- Upload & Download a control strategy from the PC.

Configuration & Setup Parameters for Redundant Controllers

- Upon initial power-up, prior to configuration, either CPU may be assigned Lead status by the system.
- Configurations are loaded into a Lead Controller only.
- The PC is connected to the Lead Controller as viewed from the indicators on the Redundant Switch Module (RSM).
- All controller data needed for synchronization between the Lead and Reserve Controllers is automatically transferred; no user-programming required.
- Single or Dual (Supervisory) Network interfaces available, no selection required.

Reserve Controller configuration

- Controller configurations loaded into the Lead Controller are automatically transferred to the Reserve Controller.
- The Reserve Controller's status indicator on the RSM is illuminated when database synchronization exists.
- Powering a Reserve CPU with an on-line Lead Controller will trigger the Lead to reprogram the Reserve.
- If both CPUs of a redundant controller are being powered with valid configurations, but only one has the desired configuration, the CPU with the desired configuration should be powered first.

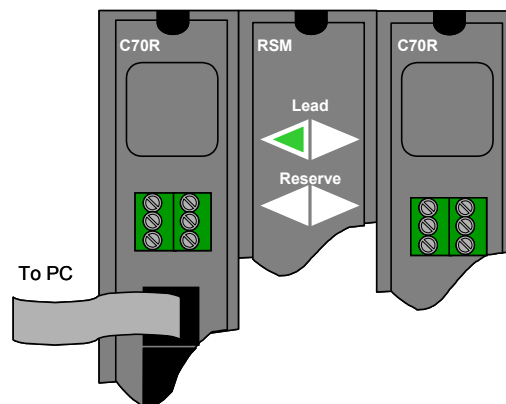

Figure 8 Connection from Lead controller to PC

Software

HC Designer & HC Utilities PC Software

- Redundant configurations require version 3.0 or later of the Designer and Utilities Software
 - The version number of the software should be equal to or greater than the version number of the controller CPU being configured.
- The same software is used to configure both redundant and non-redundant HC900 controllers.
- Supports forward migration of existing C30 and C50 configurations to the C70R.
- Software Version 3.xx or later may be used to create or modify configurations for earlier controller versions.

Downloading configuration from PC to controller

- Downloading configurations to a Lead Controller can be performed using a serial port or a network port.
 - Serial port settings use slide switches on the CPU module to determine if the port is setup for RS 232 or RS 485 operation. To setup the serial ports for the desired interface, see HC900 Hybrid Controller Installation and User Guide 51-52-25-107.
- The Lead Controller has two Ethernet ports, each supplied with a default IP address from the Honeywell factory.
 - Ethernet Port #1 (E1) is supplied with IP address 192-168-1-254 and Ethernet Port #2 (E2) is supplied with IP address 192-168-2-254. Users should change the default addresses to make them compatible with their local network.
 - IP addresses entered into the Lead Controller are automatically transferred to the Reserve Controller.
- The Reserve Controller does not communicate on a network.
 - If the Reserve Controller transitions to become a Lead Controller in a system, it assumes the network communication function for the control system.

Configuration storage

- Controller configurations downloaded to the controller are stored in battery backed RAM memory and non-volatile Flash memory.
 - The controller CPU executes its program from RAM memory. The battery backed RAM memory also stores the controller dynamic status during a loss of power to allow graceful resumption of controller operation following the interruption. If the battery is not available, startup following a power loss will use the configuration stored in Flash memory.

Configuration edits

- On-line edits to the configuration may be downloaded to the controller.
 - On-line edits made to C70R CPU configurations are stored in both RAM and Flash memory.
 - HC Designer software lets you monitor the controller's live configuration to verify edits. All edits are made to the configuration of the Lead controller. The Reserve controller's configuration is automatically updated following a change to the Lead controller's configuration.

Uploading configuration from controller to PC

- Controller configurations may be uploaded from the controller's RAM memory, and may include a user's annotations, eliminating the risk of selecting an inappropriate file from the PC's memory for editing when making changes to a running controller. Upload requests are serviced by the Lead Controller.

Downloading to multiple controllers

- Controller configuration files ending with extension .cde do not include serial port and network port setups.
 - This facilitates downloading the same configuration file to multiple controllers on the same network or serial link without creating network address duplications or bus contention problems.
 - Require the port parameters to be manually entered as a separate task while HC Designer is in communication with the controller.

Configuration backup

- Controller configurations may be uploaded and saved as Backup Files.
 - Backup files contain all of the information needed to restore a CPU to the operating conditions at the time the backup file was created, eliminating the need to for separate manual entries.
 - Useful facility to quickly get a controller back on-line following CPU replacement.
 - Backup configuration files use file extension .cbk.

Configuration conversion

- Configurations built for use with C30 and C50 CPUs may be downloaded into C70 CPUs following a file conversion performed using HC Designer software, version 3.xx or later.
 - To convert a C30 or C50 configuration files for used with C70R CPUs, open the files to be converted using HC Designer and perform a "Save As" operation and select a C70R file type.

Monitoring configurations

- Monitoring the configuration of the Lead Controller may be performed using Hybrid Control Designer software.
- Controller connection via Ethernet or serial.
- When Ethernet is used, HC Designer consumes one network socket.
- While in the monitor mode, viewing the function block diagram allows the user to view the input and output values for each function block.
- Watch windows allow viewing data by parameter type and in a user specified group.
- System Monitor (ASYS) function blocks provide an output to indicate the Reserve status of the CPU.
- Redundant controller status may be monitored from HC Designer.
- A redundancy icon is provided to allow access to information in the monitor menu.
- Selections under the Utilities Tab allow users to view diagnostic status and perform maintenance level activities.

Operation

Overview

In a redundant HC900 system, the Lead Controller performs all primary tasks including interfacing with remote I/O racks, communicating with a local HMI, exchanging data with peer controllers, interfacing with Modbus slave devices, and communicating with a Host PC application. Detection of a fault or removing power from a Reserve Controller will initiate a diagnostic prompt in the Lead Controller, but will have no impact on the process under control. The detection of a fault or removing power from a Lead Controller will initiate failover, that is, transfer all primary tasks to the Reserve Controller, establishing this controller as the new Lead. Following a failover, the new Lead Controller will remain the Lead, even if the condition that caused the failover is corrected.

Start-Up

- Assignment of Lead and Reserve status is determined at start-up
 - First available C70R assumes Lead
 - In case of a tie, CPU mounted in the left position of the rack will Lead
 - No user configuration or manual operations required to establish Lead / Reserve status
- Lead Controller assumes control of I/O and all external communication interfaces.
- Reserve Controller receives the configuration from the Lead Controller

Modes of operation

The modes of operation are:

- Run
- Run/Program
- Program

You can change modes with:

- key-switch on the redundancy control module
- HC Designer software
- HC Utilities software
- local 1042 or 449 operator interfaces.
- a command from a supervisory host

Both Lead and Reserve Controllers maintain the same mode. Placing the Lead Controller into the Program mode will also place the Reserve Controller in the Program mode.

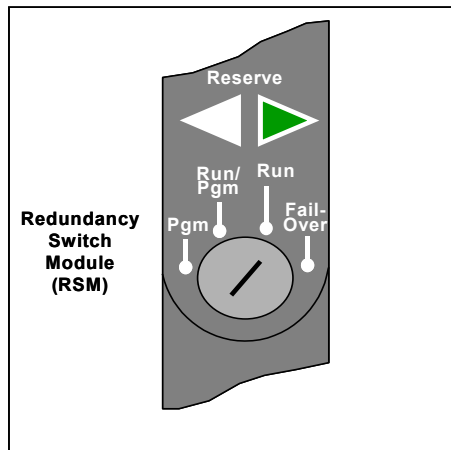

Figure 9 Modes of operation on RSM

RUN Mode (Locked)

In the Run mode, the controller performs all control and communication tasks needed for steady-state operation. On-line configuration edits and configuration changes are inhibited.

RUN/PROGRAM Mode (Unlocked)

In the Run/Program mode, steady-state tasks are executed and on-line configuration edits are permitted. Configuration changes made in this mode are retained in both RAM and Flash memory in the controller.

PROGRAM Mode (Locked)

In the program mode, all outputs are turned OFF, function blocks do not execute and configuration changes are permitted. Exiting the Program Mode performs a cold-start, which clears all timers, counters, totalizers and other function blocks with residual data. Function blocks are initialized to their initial state with no reference to previous history. Exiting the Program mode updates the RAM and Flash memory of the controller with the most recent configuration data.

Steady State Operations

- Lead Controller issues polls to I/O Racks for inputs
- Both Lead and Reserve read I/O responses from I/O Racks
- Lead and Reserve both execute function blocks in the control strategy
- Only the Lead Controller writes physical outputs to the I/O Racks
- Lead Controller responds to communication messages from host devices on the Supervisory Network and RS-232/RS-485 interfaces
- Lead Controller handles communications with HC900 peers
- Lead Controller handles communications with Modbus RTU slave devices
- Lead and Reserve exchange system status data to determine conditions for failover.
- I/O Scanners relay system status data between each Controller to determine conditions for failover

Execution time

HC900 Controllers are designed to execute control functions within fixed scan cycles for analog data types and logic data types. In redundant controllers, the minimum scan time is 533ms for analog data types and 53ms for logic data types; scan time varies depending on configuration.

Execution sequence

- The type of control functions executed during a scan is determined by the system configuration.
 - Controller configurations contain a series of algorithms in the form of function blocks that get executed in a fixed sequence. The first 100 function blocks are pre-assigned by the system to handle communication tasks, alarm processing, system monitoring functions, etc. and cannot be changed by the user. Starting with function block number 101, the user may select the type of function to be executed.
- The sequence of function block execution is initially determined by the sequence in which the function blocks are placed on the graphic diagram in HC Designer.
 - Final desired sequence must be set by the user to achieve proper and optimum performance.
 - Incorrect execution sequences can contribute to delays in processing outputs and/or improper or unexpected operation.
- The HC900 controller samples all inputs before the start of a controller scan.
 - Each input being used in the configuration must be assigned to a function block. The sequence order of the function block determines when in time the actual value will be updated. It is important that algorithms that need updated input values for their calculations have the inputs execute first in the sequence.
- Except for Time Proportioning Output (TPO), Three-Position-Step-Control (TPSC) and Position Proportional Output (PPO) function block types that update their physical output values while the function blocks are being executed, all physical outputs are updated at the end of a scan.

Lead/Reserve controller synchronization

- Lead Controller automatically synchronizes the Reserve with the configuration database
 - During download of a configuration from a Host to the Lead
 - During process operation to bring a Reserve Controller from the Unavailable state to the On-Line state
- Lead Controller automatically synchronizes the Reserve with run-time data during each function block execution cycle
- Both the Lead and Reserve Controllers execute the function blocks in the control strategy, but only the Lead Controller writes the physical outputs to the I/O Racks. See Figure 10.
- The Lead and Reserve controllers exchange system status to determine conditions for failover.

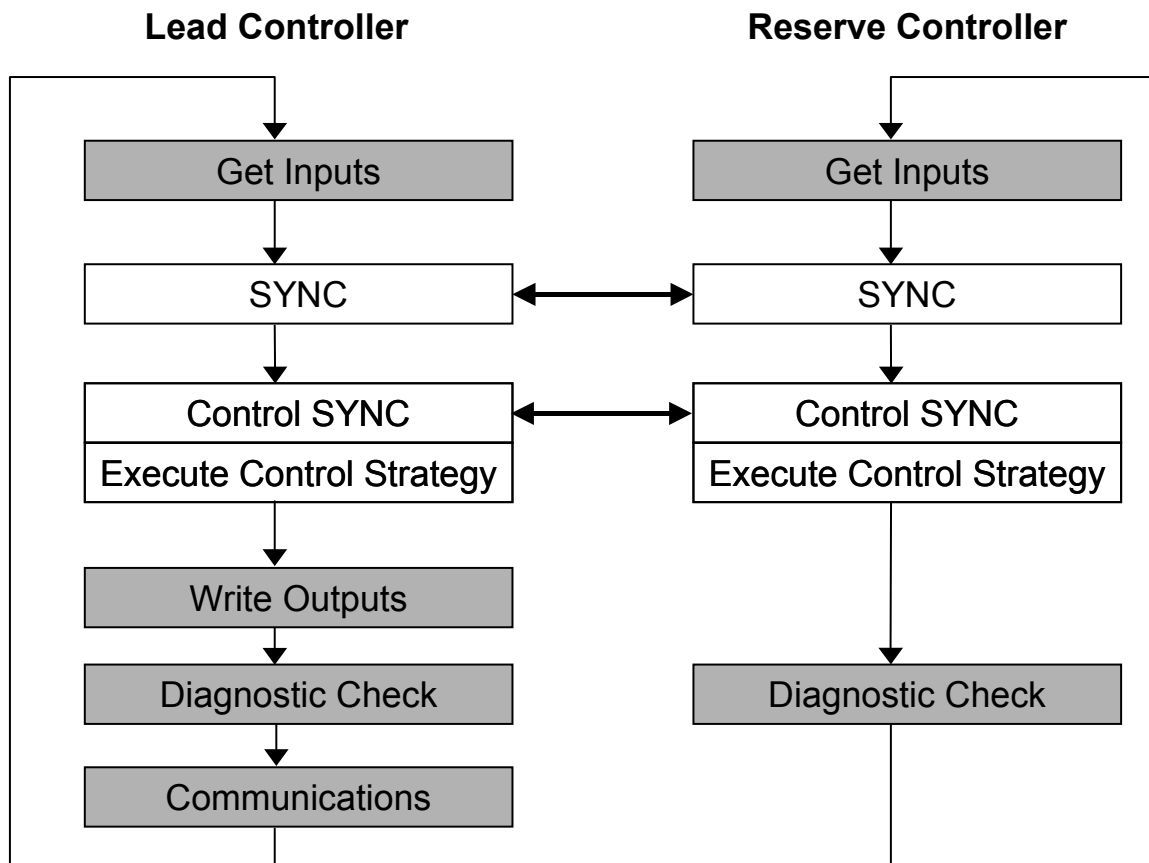

Figure 10 Lead/Controller synchronization

Failover

Automatic Failover

- Triggered on any of the following conditions of the Lead Controller:
 - Loss of communications with I/O Rack(s)
 - Processor exception conditions
- Error conditions that occur in the following areas will not cause a failover:
 - Loss of communications to a Host on a network
 - Loss of communications to Modbus Slave devices
 - Loss of communications to Operator Interface
 - Loss of communications with a Peer controller
- During the transition from the Lead to the Reserve, analog and digital output status is maintained at the I/O racks.

Manual Failover

- Via Key Switch on the Redundancy Switch Module in the Redundant Controller Rack
- Via Software Command from HC Designer & HC Utilities PC Software
- Via Software Command from Modbus / TCP & Serial Modbus RTU Hosts
- Via Software Command from OI-1042 & OI-559 Operator Interfaces

Failover Performance

Failure condition detection and failover from Lead to Reserve CPU executed in 4 analog control cycles or less.

Redundancy Diagnostic Monitoring

- From HC Designer and HC Utilities PC Software
 - Redundant System Status - current status of Lead/Reserve Controller CPU's
 - On-Line Monitoring, Controller Diagnostics, Communications Loop-Back tests
 - Redundant Link Status – status of communications between Lead and Reserve controllers.
 - Lead CPU status
 - Reserve CPU status
 - Scanner status

Installation

Installing the Redundant Controller Rack

- Rack must be installed in an enclosure and oriented for ventilation with mounting holes on top and bottom
- A Redundancy Switch Module (RSM) mounts in the center slot of the rack
- One Power Supply and C70R Controller mount to the left of the RSM
- One Power Supply and C70R Controller mount to the right of the RSM
- Ethernet ports (E1 & E2) are host network ports
- Ethernet port (labeled I/O) is the dedicated I/O rack port
- An optional Honeywell Operator Interface connects to Serial port S2
- Power with over-current protection and separate disconnects should be connected to each Power Supply

Installing the I/O Racks

- Rack must be installed in an enclosure and oriented for ventilation with mounting holes at top and bottom of rack
- When installing a single Power Supply in the rack:
 - The Power Supply mounts in the first slot on the left in the rack.
- When installing redundant Power Supplies in the proper rack to support this feature:
 - Mount the Power Status Module (PSM) to the left of the first power supply.
 - The second Power Supply installs to the left of the PSM.
- A Scanner2 CPU mounts to the right of the Power Supply.
- I/O Modules mount to the right of the Scanner2 module.
- Power with over-current protection and separate disconnects should be connected to each Power Supply.

Installing Networking Equipment

I/O Network

- Required for configurations using multiple I/O Racks; Not required for configurations using only one I/O Rack.
- Must use Honeywell qualified industrial hubs between controller rack and I/O Racks (PN 50008930-001)
- Follow installation instructions in HC900 Hybrid Controller Installation and User Guide 51-52-25-107.
- Use a separate hub for each C70R Controller CPU.
- Each Scanner2 connects to both hubs using consistent port assignments for each I/O rack.
- Only use Shielded CAT 5 cable for network connections.

Supervisory / Peer Network

- Any switching device that meets the specifications for the specific site can be used.
- Follow the supplier's installation instructions
- Each C70R CPU connects to each switching device
- Use consistent C70R port assignments when connecting the CPUs to their respective switching devices.
- Only use shielded CAT5 cable for Supervisory/Peer Network connections.

Installing a Panel-Mounted Operator Interface

Honeywell OI-1042 & OI-559

- Follow panel-mounting instructions provided with the interface.
- The RS-485 Serial Interface is Daisy-chained to both C70R Controllers
- Use the same serial port, S1 or S2 on both C70R CPUs.

3rd Party Panel-Mounted OI

- Follow the supplier's installation instructions
- The RS-485 Serial Interface is Daisy-chained to both C70R Controllers
- Use the same serial port, S1 or S2 on both C70R CPUs.

Installing PC Hosts

Honeywell HC Designer & HC Utilities Software

- Operating Systems supported: Windows 2000, NT, XP Professional
- PC hardware requirements:
 - Pentium 200 MHz with 64 MB of RAM
 - Screen resolution – SVGA (1024x768 recommended)
 - CD ROM drive (for loading software)
- Connects to the C70R Controllers using Ethernet, RS-232, Modbus RTU, or Modem
- Available on CD

Honeywell Vista Software

- See document 51-52-03-38 PlantScape Vista Specification
- Connects to the C70R Controllers using Ethernet
- Interfaced through Honeywell-supplied OPC Server for redundant networks or embedded drive
- For simplex connections

3rd Party PC Application Software

- Interfaced through Honeywell-supplied OPC Server
- Requires 3rd Party PC Software to be an OPC Client
- Connect to the C70R Controllers using Ethernet
- OPC Server available on CD

Troubleshooting

Diagnostic Indicators

- LEDs on the front of each module are provided to indicate the module's health. These include:
 - C70R Controller Status LEDs
 - Scanner2 Status LEDs
 - I/O Module Status LEDs
- The HC900 modules use a combination of color and flashing patterns to indicate fault conditions and the type of fault detected. See the HC900 controller manual for a detailed explanation of fault conditions.
- LEDs on the front of the Redundancy Switch Module indicate the Lead/Reserve status of the two redundant C70R Controllers
 - Reserve indicator will flash while Reserve CPU is being updated by Lead.
 - Reserve controller is not available during this period.
- LEDs on the front of the Power Status Module indicate the status of the redundant Power Supplies for an I/O Rack
 - ON if the power supply is functioning properly
 - Off if either the 5 volt or the 24 volt source of a power supply has a fault.

Diagnostic Monitoring from HC Designer and HC Utilities PC Software

- Monitor the current status of Lead/Reserve Controller CPU's
- View a Historical log of controller failover events
- Monitor Lead controller function block execution
- View controller diagnostic status
- Perform communications Loop-Back tests

Status data available via Supervisory PC

- Current status of Lead/Reserve Controller CPU's
- Status of I/O Rack Power, including optional redundant power supplies

Servicing

Module Replacement

- Servicing a failed module is accomplished by replacing only that module

C70R Module Replacement

- Requires power for the module to be turned off during replacement
- Does not impact the other C70R CPU module, which will continue to control the process
- Contains start-up diagnostics after replacement to verify proper operation
- If there is a Lead Controller, the configuration database is automatically copied from the Lead to the newly replaced C70R CPU module.

Redundancy Switch Module Replacement

- May be removed or inserted under power
- The C70R CPU modules will remain in the last used mode while the Redundancy Switch Module is removed.
- Does not induce a controller failover during replacement

Scanner2 Module Replacement

- Requires power to the rack to be turned off during replacement
- I/O in the rack will be powered off during Scanner2 module replacement
- Redundant controllers will operate with the affected I/O in failsafe state during Scanner2 module replacement
- Does not impact other I/O Racks in the same configuration
- Contains start-up diagnostics after replacement to verify proper operation

C70R Power Supply Replacement

- Requires power for the module to be turned off during replacement, which supplies power to a single C70R CPU
- Does not impact the other C70R CPU module, which will continue to control the process

Non-Redundant Power Supply for I/O Rack Replacement

- Requires power for the module to be turned off during replacement, which supplies power to a single I/O Rack

Optional Redundant Power Supply for I/O Rack Replacement

- Requires power for the module to be turned off during replacement
- Power is maintained for the I/O Rack by the other Power Supply of the redundant pair

Power Status Module Replacement

- May be removed or inserted under power
- No impact on the Scanner2 or I/O modules during replacement

I/O Module Replacement

- May be removed or inserted under power
- Removable terminal blocks preserve field wiring during module replacement
- Removal of the module is detected by the Scanner2 and a diagnostic is posted
- Contains start-up diagnostics after replacement to verify proper operation

Sales and Service

For application assistance, current specifications, pricing, or name of the nearest Authorized Distributor, contact one of the offices below.

ARGENTINA

HONEYWELL S.A.I.C.
BELGRANO 1156
BUENOS AIRES
ARGENTINA
Tel. : 54 1 383 9290

ASIA PACIFIC

HONEYWELL ASIA
PACIFIC Inc.
Room 3213-3225
Sun Kung Kai Centre
N° 30 Harbour Road
WANCHAI
HONG KONG
Tel. : 852 829 82 98

AUSTRALIA

HONEYWELL LIMITED
5 Thomas Holt Drive
North Ryde Sydney
NSW AUSTRALIA 2113
Tel. : 61 2 353 7000
AUSTRIA

HONEYWELL AUSTRIA

G.m.b.H.
Handelskai 388
A1020 VIENNA
AUSTRIA
Tel. : 43 1 727 800

BELGIUM

HONEYWELL S.A.
3 Avenue de Bourget
B-1140 BRUSSELS
BELGIUM
Tel. : 32 2 728 27 11

BRAZIL

HONEYWELL DO
BRAZIL
AND CIA
Rua Jose Alves Da
Chunha
Lima 172
BUTANTA
05360.050 SAO PAULO
SP
BRAZIL
Tel. : 55 11 819 3755

BULGARIA

HONEYWELL EOOD
14, Iskarsko Chausse
POB 79
BG- 1592 Sofia
BULGARIA
Tel. : 359-791512/
794027/ 792198

CANADA

HONEYWELL LIMITED
THE HONEYWELL
CENTRE
300 Yorkland Blvd.
NORTH YORK,
ONTARIO
M2J 1S1
CANADA
Tel.: 800 461 0013
Fax.: 416 502 5001

CZECH

REPUBLIC
HONEYWELL,
Spol.s.r.o.
Budejovicka 1
140 21 Prague 4
Czech Republic
Tel. : 42 2 6112 3434

DENMARK

HONEYWELL A/S
Automatikvej 1
DK 2860 Soeborg
DENMARK
Tel. : 45 39 55 56 58

FINLAND

HONEYWELL OY
Ruukintie 8
FIN-02320 ESPOO 32
FINLAND
Tel. : 358 0 3480101

FRANCE

HONEYWELL S.A.
Bâtiment « le Mercury »
Parc Technologique de
St
Aubin
Route de l'Orme
(CD 128)
91190 SAINT-AUBIN
FRANCE
Tel. from France:
01 60 19 80 00
From other countries:
33 1 60 19 80 00

GERMANY

HONEYWELL AG
Kaiserleistrasse 39
D-63067 OFFENBACH
GERMANY
Tel. : 49 69 80 64444

HUNGARY

HONEYWELL Kft
Gogol u 13
H-1133 BUDAPEST
HUNGARY
Tel. : 36 1 451 43 00

ICELAND

HONEYWELL
Hataekni .hf
Armuli 26
PO Box 8336
128 reykjavik
Iceland
Tel : 354 588 5000

ITALY

HONEYWELL S.p.A.
Via P. Gobetti, 2/b
20063 Cernusco Sul
Naviglio
ITALY
Tel. : 39 02 92146 1

MEXICO

HONEYWELL S.A. DE
CV
AV. CONSTITUYENTES
900
COL. LOMAS ALTAS
11950 MEXICO CITY
MEXICO
Tel : 52 5 259 1966

THE NETHERLANDS

HONEYWELL BV
Laaderhoogweg 18
1101 EA AMSTERDAM
ZO
THE NETHERLANDS
Tel : 31 20 56 56 911

NORWAY

HONEYWELL A/S
Askerveien 61
PO Box 263
N-1371 ASKER
NORWAY
Tel. : 47 66 76 20 00

POLAND

HONEYWELL Sp.z.o.o
Ul Domainewksa 41
02-672 WARSAW
POLAND
Tel. : 48 22 606 09 00

PORTUGAL

HONEYWELL
PORTUGAL LDA
Edificio Suecia II
Av. do Forte nr 3 - Piso
3
2795 CARNAXIDE
PORTUGAL
Tel. : 351 1 424 50 00

REPUBLIC OF IRELAND

HONEYWELL
Unit 1
Robinhood Business
Park
Robinhood Road
DUBLIN 22
Republic of Ireland
Tel. : 353 1 4565944

REPUBLIC OF SINGAPORE

HONEYWELL PTE LTD
BLOCK 750E CHAI
CHEE ROAD
06-01 CHAI CHEE IND.
PARK
1646 SINGAPORE
REP. OF SINGAPORE
Tel. : 65 2490 100

REPUBLIC OF SOUTH AFRICA

HONEYWELL
Southern Africa
PO BOX 138
Milneron 7435
REPUBLIC OF SOUTH
AFRICA
Tel. : 27 11 805 12 01

ROMANIA

HONEYWELL Office
Bucharest
147 Aurel Vlaicu Str.,
Sc.Z.,
Apt 61/62
R-72921 Bucharest
ROMANIA
Tel : 40-1 211 00 76/
211 79

RUSSIA

HONEYWELL INC
4 th Floor Administrative
Building of AO
"Luzhniki"
Management
24 Luzhniki
119048 Moscow
RUSSIA
Tel : 7 095 796 98 00/01

SLOVAKIA

HONEYWELL Ltd
Mlynske nivy 73
PO Box 75
820 07 BRATISLAVA 27
SLOVAKIA
Tel. : 421 7 52 47 400/
425

SPAIN

HONEYWELL S.A
Factory
Josefa Valcarcel, 24
28027 MADRID
SPAIN
Tel. : 34 91 31 3 61 00

SWEDEN

HONEYWELL A.B.
S-127 86 Skarholmen
STOCKHOLM
SWEDEN
Tel. : 46 8 775 55 00

SWITZERLAND

HONEYWELL A.G.
Hertistrasse 2
8304 WALLISELLEN
SWITZERLAND
Tel. : 41 1 831 02 71

TURKEY

HONEYWELL
Otomasyon ve Kontrol
Sistemlen San ve Tic
A.S.
(Honeywell Turkey A.S.)
Emirhan Cad No 144
Barbaros Plaza C. Blok
Kat 18
Dikilitas 80700 Istanbul
TURKEY
Tel : 90-212 258 18 30

UNITED KINGDOM

HONEYWELL CONTROL
SYSTEMS LTD
Industrial Measurement
and Control CRC
Lovelace Road
Southern Industrial Area
Bracknell
Berks
RG12 8WD
Tel: 01344 655034
Fax: 01344 655554

U.S.A.

HONEYWELL INC.
INDUSTRIAL
PROCESS CONTROLS
1100 VIRGINIA DRIVE
PA 19034-3260
FT. WASHINGTON
U.S.A.
Tel. : 1-800-343-0228

VENEZUELA

HONEYWELL CA
APARTADO 61314
1060 CARACAS
VENEZUELA
Tel. : 58 2 239 0211

Honeywell

Industrial Measurement and Control

Honeywell

1100 Virginia Drive

Fort Washington, PA 19034